

Monitoring Relays

1-Phase True RMS AC/DC Over or Under Current

Types DIB02, PIB02



- TRMS AC/DC over or under current monitoring relays
- Current measuring through external shunt or CT
- Selection of measuring range by DIP-switches
- Measuring ranges from 6 to 150 mV AC/DC and 0.4 to 4 V_p AC (MI or MP range)
- Adjustable current on relative scale
- Adjustable hysteresis on relative scale
- Adjustable delay function (0.1 to 30 s)
- Programmable latching or inhibit at set level
- Output: 8 A SPDT relay N.D. or N.E. selectable
- For mounting on DIN-rail in accordance with DIN/EN 50 022 (DIB02) or plug-in module (PIB02)
- 22.5 mm Euronorm housing (DIB02) or 36 mm plug-in module (PIB02)
- LED indication for relay, alarm and power supply ON
- Galvanically separated power supply

Product Description

DIB02 and PIB02 are precise TRMS AC/DC over or under current (selectable by DIP-switch) monitoring relays. The current is measured through an external shunt. 1-phase and 3-phase current up to 500 AAC can be monitored connecting MI or MP current transformers.

Owing to the built-in latch function, the ON-position of the relay output can be maintained. Inhibit function can be used to avoid relay operation when not desired (maintenance, transitions). The LED's indicate the state of the alarm and the output relay.

Ordering Key **DIB 02 C B23 150mV**

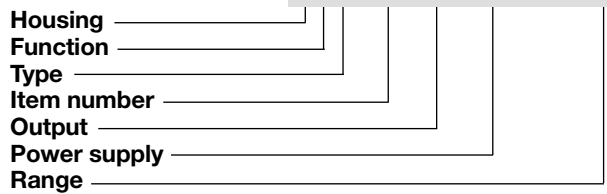

Type Selection

Mounting	Output	Supply: 24 VDC	Supply: 48 VDC	Supply: 24/48 VAC	Supply: 115/230 VAC
DIN-rail	SPDT	DIB 02 C 724 150MV	DIB 02 C 748 150MV	DIB 02 C B48 150MV	DIB 02 C B23 150MV
Plug-in	SPDT	PIB 02 C 724 150MV	PIB 02 C 748 150MV	PIB 02 C B48 150MV	PIB 02 C B23 150MV

Input Specifications

Input	DIB02: Terminals Y1, Y2 PIB02: Terminals 5, 7	
Voltage level		
Measuring ranges	Internal resis.	Max. volt.
6 to 60 mV AC/DC	1 kΩ	2 V
15 to 150 mV AC/DC	1 kΩ	2 V
Max. voltage for 1 s		15 V
0.4 to 4 V _p AC	50 kΩ	50 V
Max. voltage for 1 s		100 V
MI and MP CT ranges	AAC rms	Max. curr.
1-ph.: 3-ph.:		
MI 5 MP 3005	0.5 to 5 A	20 AAC
MI 20 MP 3020	2 to 20 A	50 AAC
MI 100 MP 3100	10 to 100 A	250 AAC
MI 500 MP 3500	50 to 500 A	750 AAC

Note:
The input voltage cannot raise over 300 VAC/DC with respect to ground (PIB02 only)

Input Specifications (cont.)

Note: MP3... current transformers not suitable for under current measurement due to the output signal of the device (see data sheet)	
Contact input	
DIB02	Terminals Z1, Y1
PIB02	Terminals 8, 9
Disabled	> 10 kΩ
Enabled	< 500 Ω
Latch disable	> 500 ms



Output Specifications

Output	SPDT relay
Rated insulation voltage	250 VAC
Contact ratings (AgSnO₂)	μ
Resistive loads AC 1	8 A @ 250 VAC
DC 12	5 A @ 24 VDC
Small inductive loads AC 15	2.5 A @ 250 VAC
DC 13	2.5 A @ 24 VDC
Mechanical life	≥ 30 x 10 ⁶ operations
Electrical life	≥ 10 ⁵ operations (at 8 A, 250 V, cos φ = 1)
Operating frequency	≤ 7200 operations/h
Dielectric strength	
Dielectric voltage	≥ 2 kVAC (rms)
Rated impulse withstand volt.	4 kV (1.2/50 μs)

Supply Specifications

Power supply	Overvoltage cat. III (IEC 60664, IEC 60038)	
Rated operational voltage through terminals:		
A1, A2 or A3, A2 (DIB02)		
2, 10 or 11, 10 (PIB02)		
724:	24 VDC ± 20%, insulated	
748:	48 VDC ± 20%, insulated	
B48:	24/48 VAC ± 15% 45 to 65 Hz, insulated	
B23:	115/230 VAC ± 15% 45 to 65 Hz, insulated	
Dielectric voltage	DC supply	AC supply
Supply to input	2 kV	4 kV
Supply to output	4 kV	4 kV
Input to output	4 kV	4 kV
Rated operational power		
AC	4 VA	
DC	3 W	

Mode of Operation

DIB02 and PIB02 monitor both AC and DC over or under current through an external shunt.

When connected with MI or MP current transformer (using the 0.4 to 4 V_p range) they can monitor 1-phase or 3-phase AC current up to 500 A.

Example 1

(connection between terminals Z1, Y1 or 8, 9 - latching function enabled)

The relay operates and latches in operating position when the measured value

exceeds (or drops below) the set level for more than the set delay time.

Provided that the current has dropped below (or has exceeded) the set point (see hysteresis setting), the relay releases when the interconnection between terminals Z1, Y1 or 8, 9 is interrupted or the power supply is interrupted as well.

The red LED flashes until the delay time has expired or the measured value comes back to a non-alarm value (see hysteresis setting).

General Specifications

Power ON delay	1 s ± 0.5 s or 6 s ± 0.5 s
Reaction time	(input signal variation from -20% to +20% or from +20% to -20% of set value)
Alarm ON delay	< 100 ms
Alarm OFF delay	< 100 ms
Accuracy	(15 min warm-up time)
Temperature drift	± 1000 ppm/°C
Delay ON alarm	± 10% on set value ± 50 ms
Repeatability	± 0.5% on full-scale
Indication for	
Power supply ON	LED, green
Alarm ON	LED, red (flashing 2 Hz during delay time)
Output relay ON	LED, yellow
Environment	(EN 60529)
Degree of protection	IP 20
Pollution degree	3 (DIB02), 2 (PIB02)
Operating temperature	-20 to 60°C, R.H. < 95%
Storage temperature	-30 to 80°C, R.H. < 95%
Housing dimensions	
DIn-rail version	22.5 x 80 x 99.5 mm
Plug-in version	36 x 80 x 87 mm
Weight	Approx. 150 g
Screw terminals	
Tightening torque	Max. 0.5 Nm acc. to IEC 60947
Approvals	UL, CSA (except 748)
CE Marking	Yes
EMC	
Immunity	Electromagnetic Compatibility
Emission	According to EN 61000-6-2 According to EN 50081-1

Example 2 (MI CT)

(no connection between terminals Z1, Y1 or 8, 9 - latch function disabled)

The relay operates when the current flowing in the CT exceeds (or drops below) the set level for more than the set delay time.

It releases when the current drops below (or exceeds) the set level (see hysteresis setting) or when power supply is interrupted.

Example 3 (MP CT)

(no connection between terminals Z1, Y1 or 8, 9 - latch

function disabled - over current measurement)

The relay operates when the maximum current flowing in the CT exceeds the set level for more than the set delay time.

It releases when the maximum current drops below the set level (see hysteresis setting) or when power supply is interrupted.

Note

When the inhibit contact is opened, if the input signal is already in alarm position, the delay time needs to elapse before relay activation.

Function/Range/Level and Time Delay Setting

Adjust the measuring range setting the DIP switches 1 and 2 and select the desired function setting the DIP switches 3 to 6 as shown below.

To access the DIP switches open the grey plastic cover as shown below.

Selection of level and time delay:

Upper knob:
Setting of hysteresis on relative scale: 0 to 30% on set value.

Centre knob:
Current level setting on relative scale: 10 to 110% on full scale.

Lower knob:
Setting of delay on alarm time on absolute scale (0.1 to 30 s).

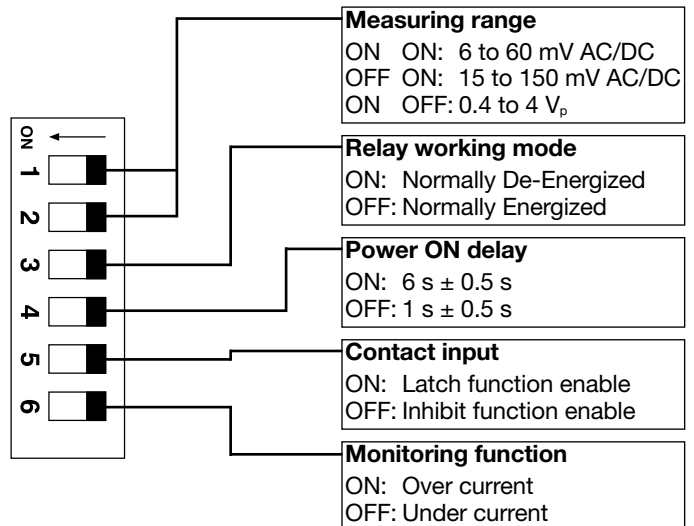
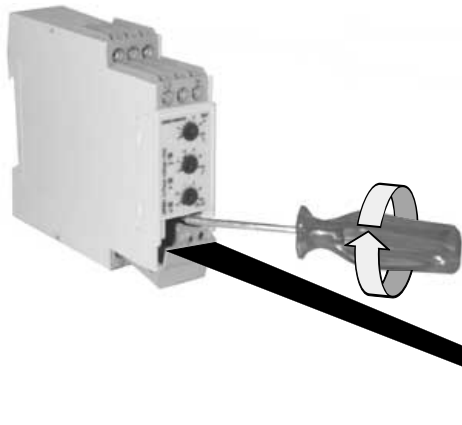

Dimensions

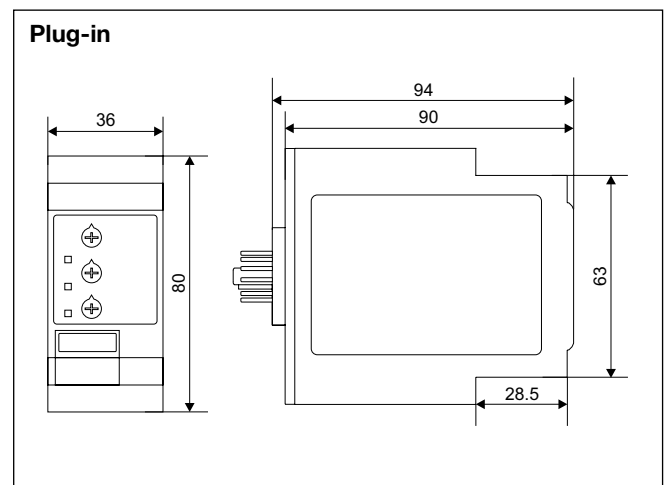
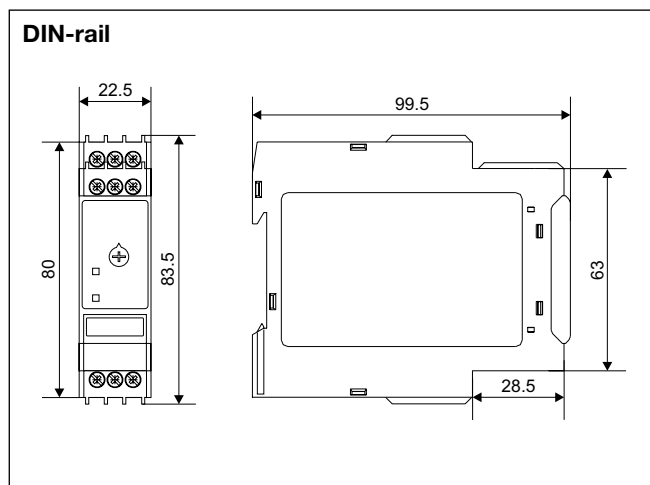

Wiring Diagrams

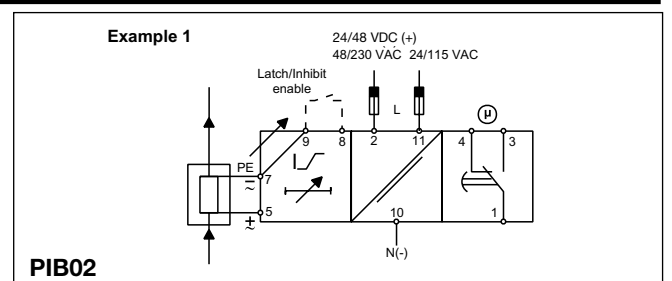
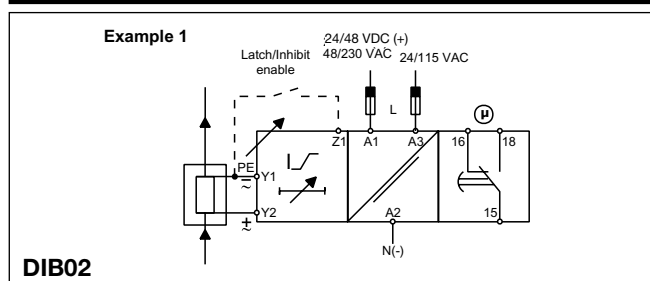



Wiring Diagrams (cont.)

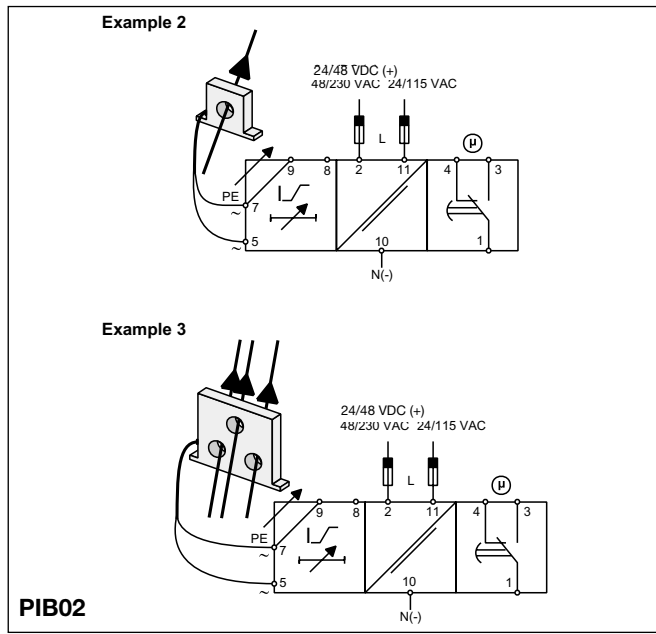
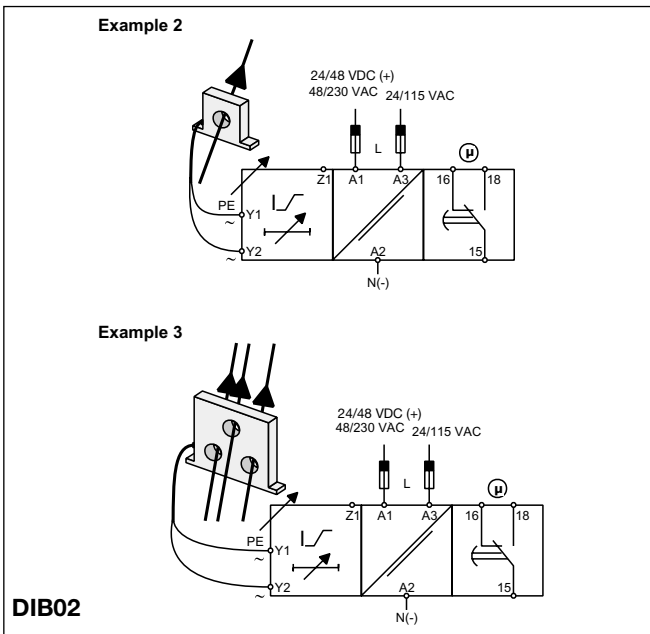

Operation Diagrams

Over current - N.D. relay

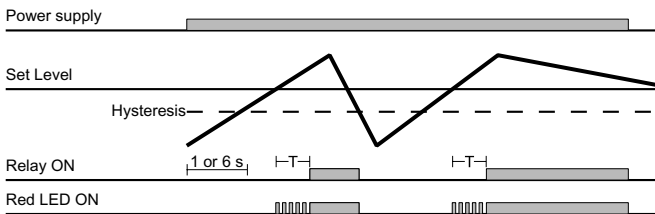

Under current - Latch function - N.D. relay

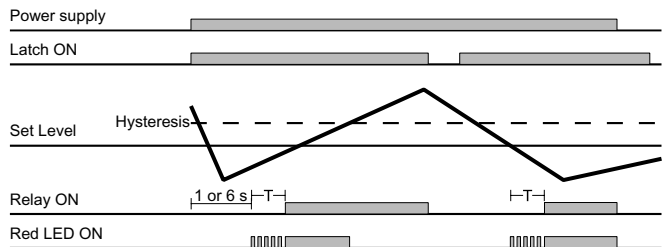

Under current - N.D. relay

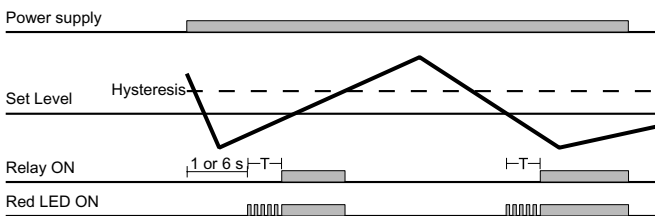

Over current - Inhibit function - N.D. relay

